

Metallurgical challenges in WEEE recycling

Simulation of a P.S. Converter using SimuSage

Andreas Lennartsson, Caisa Samuelsson,
Theo Lehner

Luleå University of Technology
Boliden Mineral AB

Background

- Industrial
 - Economic
 - EH&S
 - Physical separation
 - Production and product quality
- Research
 - Development of new processes (hydro – pyrometallurgical)
- You and me
 - Separate collection of ALL WEEE

Definitions



WEEE

E-scrap for
smelters



The KALDO

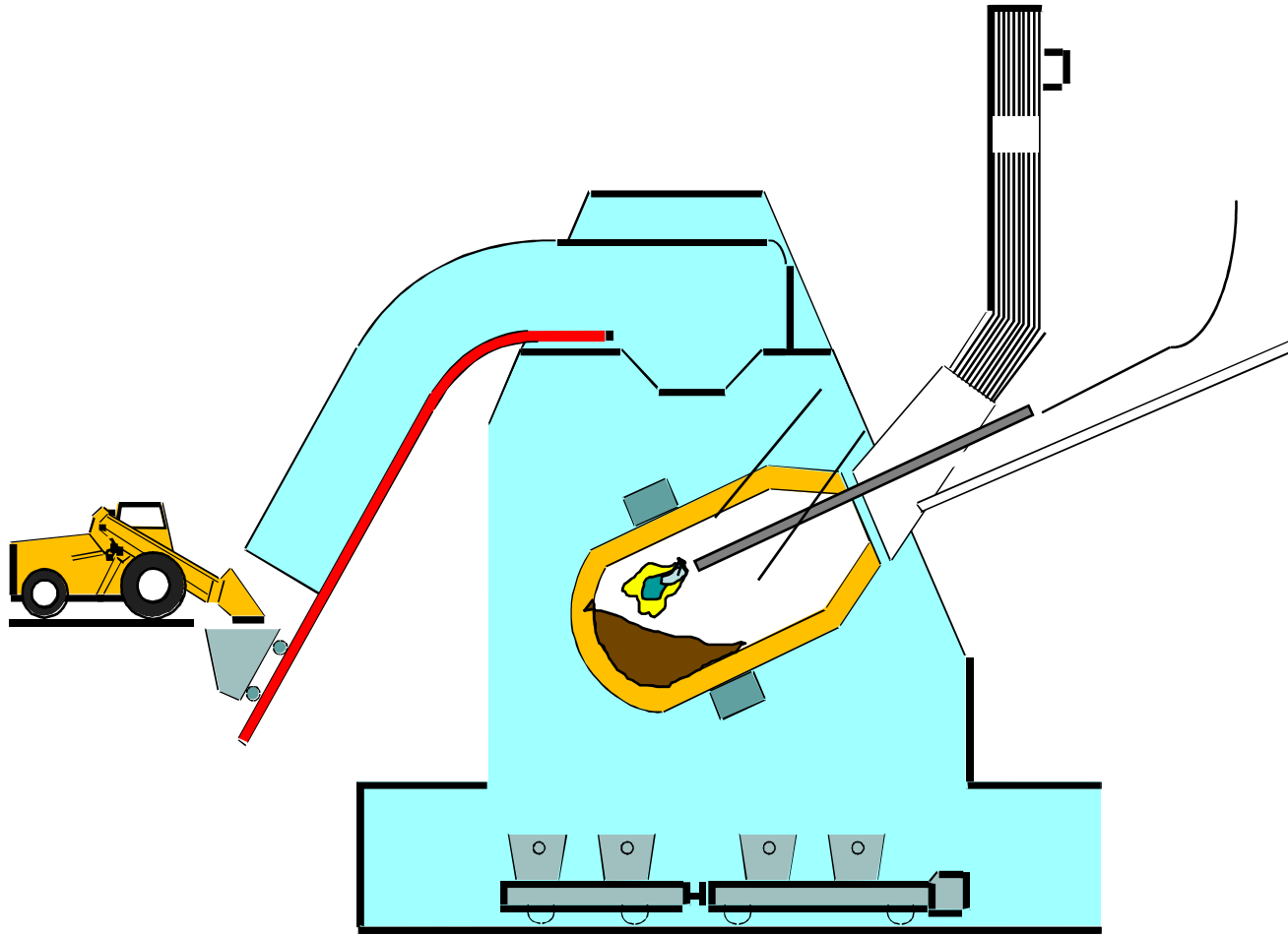

More than 30 years of experience in e-scrap smelting and recycling

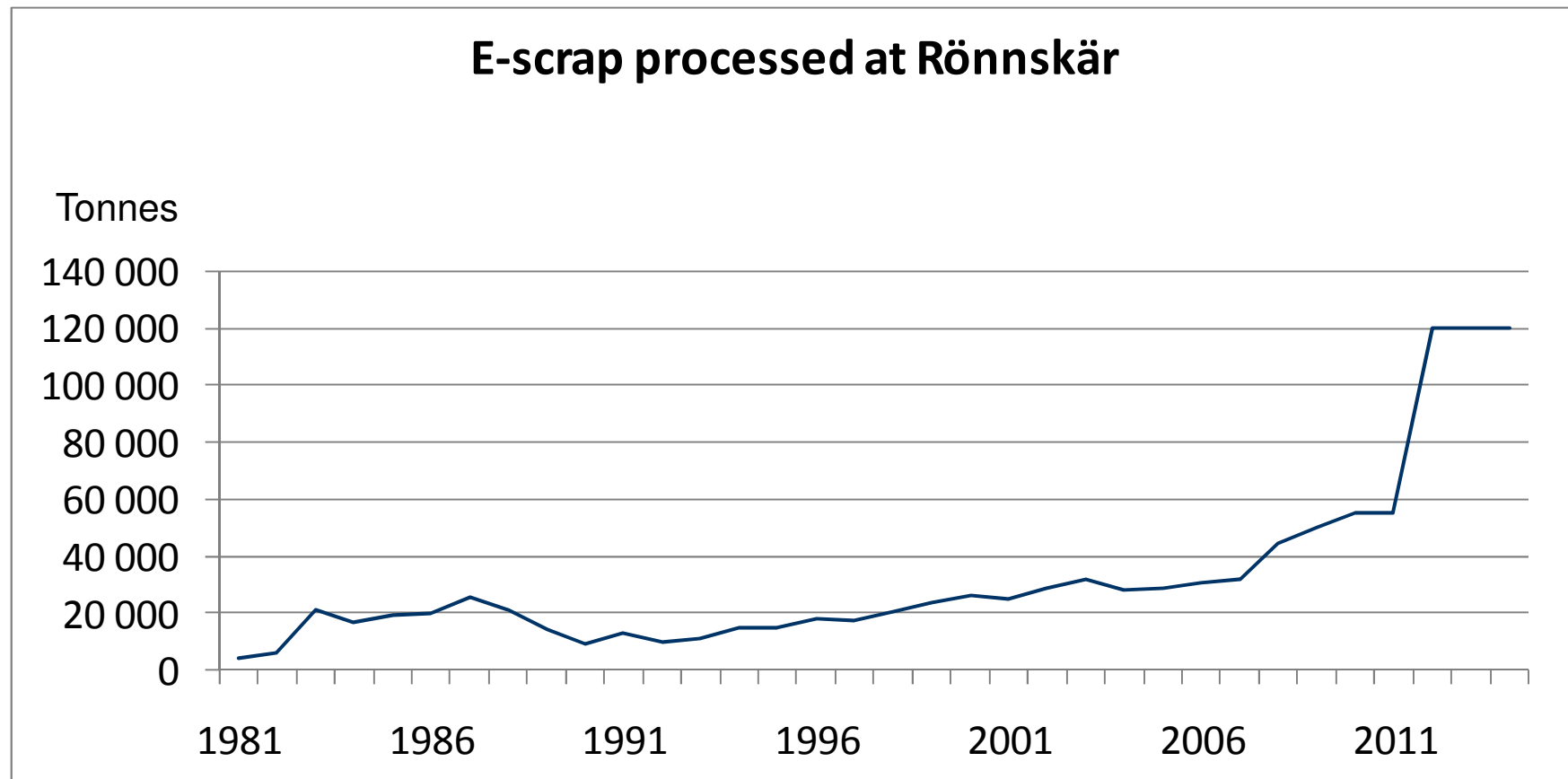

Copper flow at Boliden Rönnskär

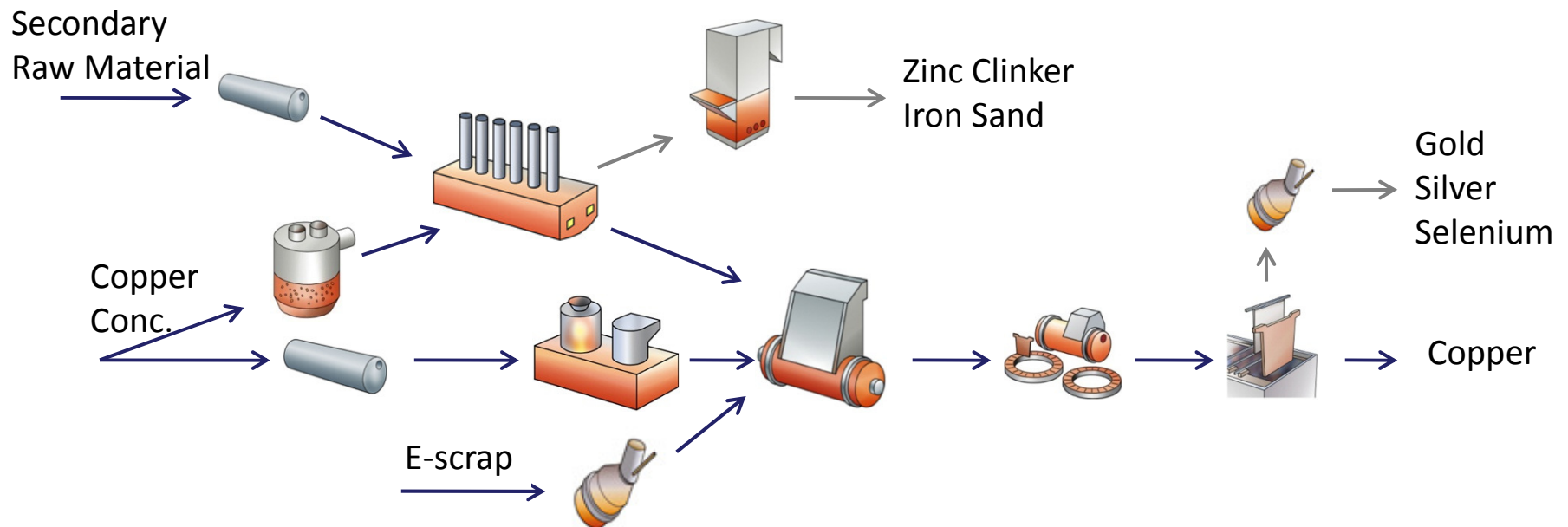

Challenges in modelling a P.S. Converter

- Non-ideal behavior
- Non-equilibria processes
- Minor elements not assessed for the system
- More than obvious phases (e.g. several mattes, immiscible slags, dispersions)
- Include non-equilibrium
- Include minor elements to liquid sulphide, slag and liquid metal

Include Non-equilibrium

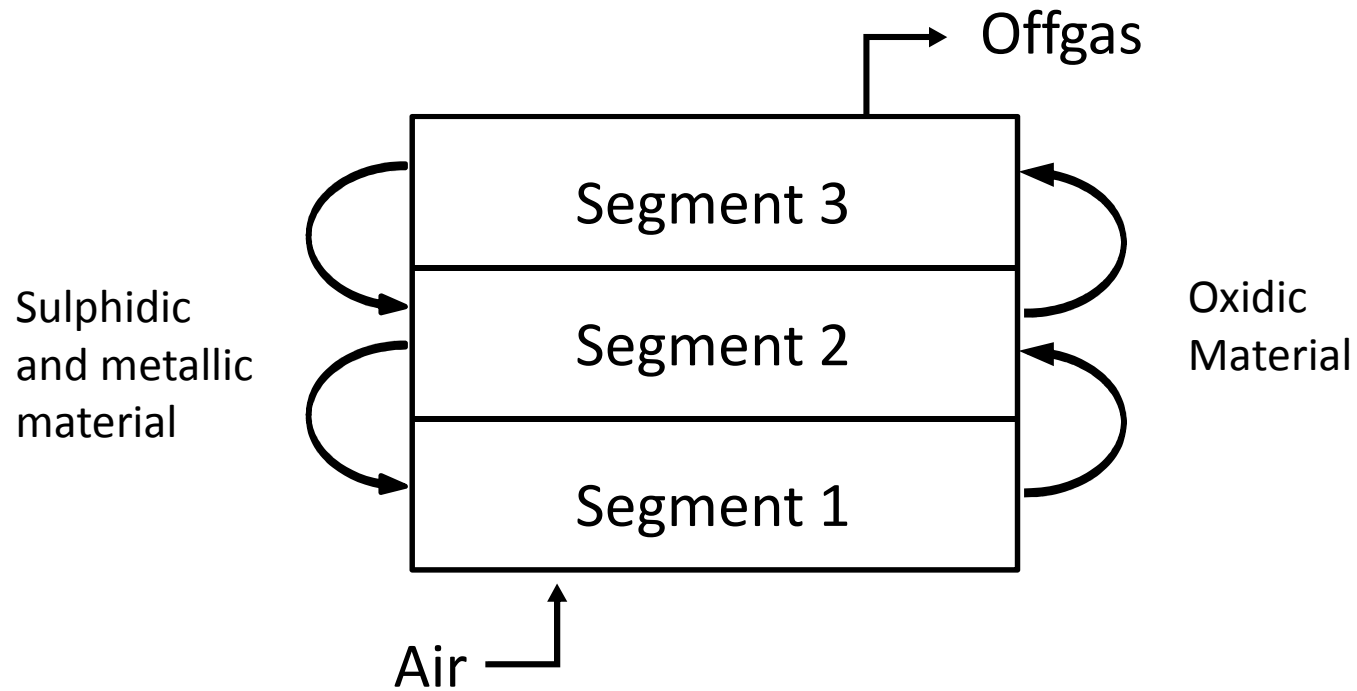

Include Non-equilibrium

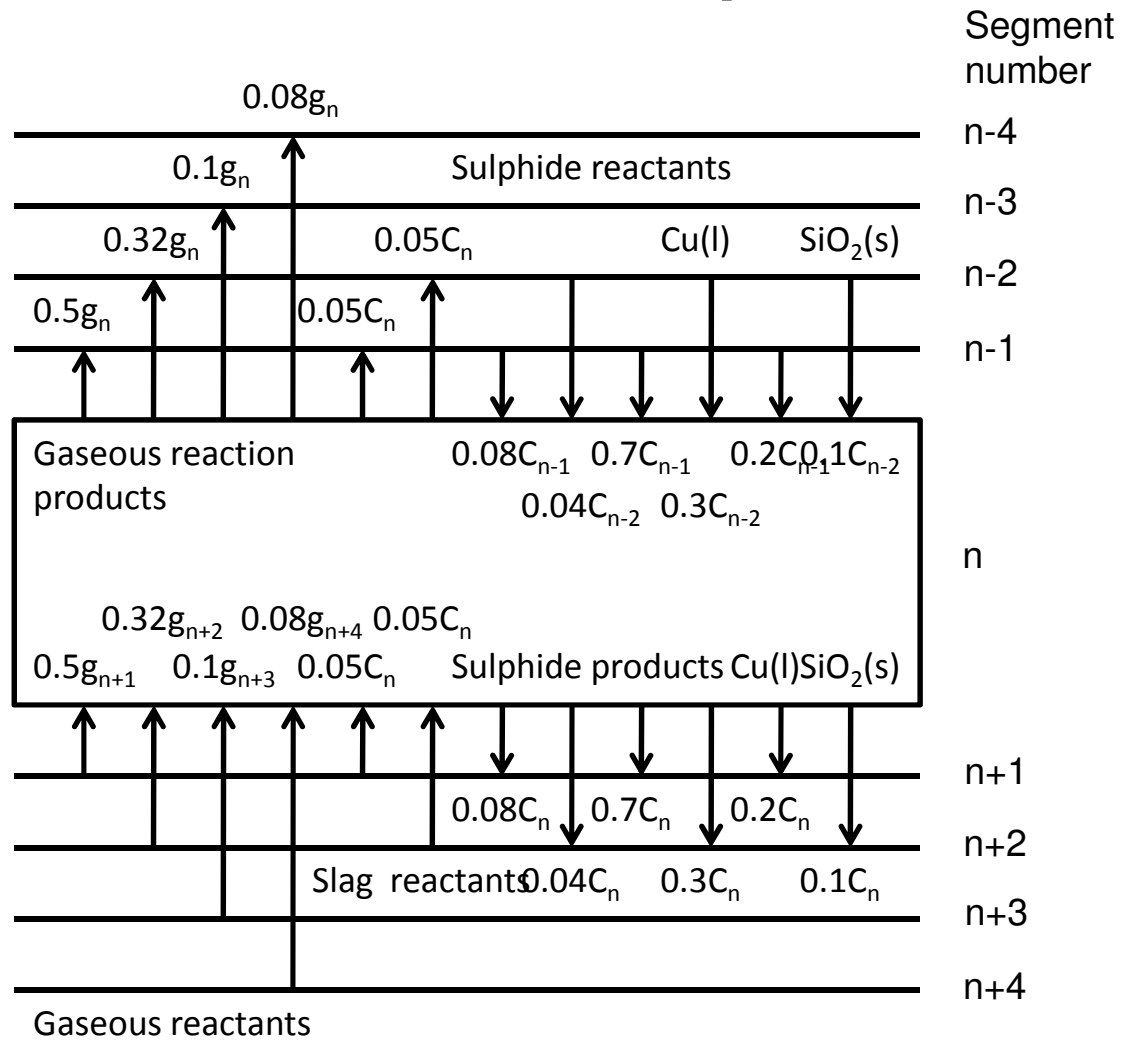

Energy balance

- Heat of reaction
- Radiation
 - converter mouth
- Refractory

$$q_{ref} = m_{ref} \cdot C_{P_{ref}} \cdot \frac{\Delta T}{2}$$

- Constant surface temperature

- Bath temperature is an average of the 3 segments

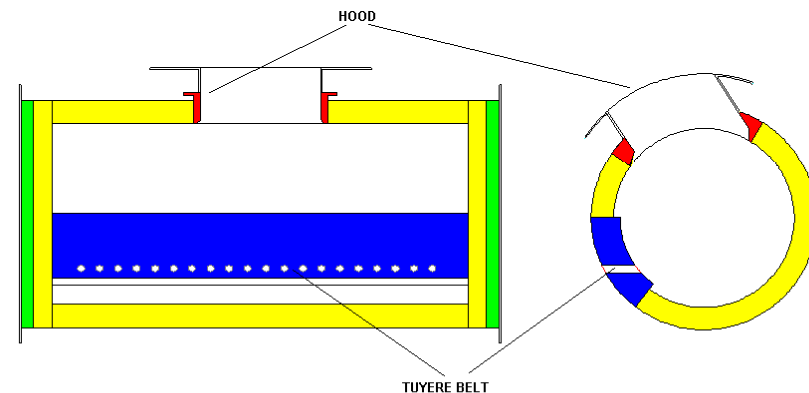

Simulation Results

Slag Blowing Step

Input	Mass [ton]
Matte	283
Copper blowing slag	41
Solids and E-scrap	96

White metal	Plant data	Simulation	Slag	Plant data	Simulation
Fe [%]	0.9	0.1	Fe [%]	30	27
Cu [%]	76.4	77.6	Cu [%]	6.5	5.2
Pb [%]	0.5	1.1	Pb [%]	5.2	6.2
As [%]	0.1	0.1	As [%]	0.01	0.07
Sb [%]	0.1	0.2	Sb [%]	0.1	0.1
S [%]	17.7	19.8	S [%]	0.4	0.02
Bi [%]	0.01	0.04	Bi [%]	0.002	<0.001

Simulation Results

Slag Blowing Step

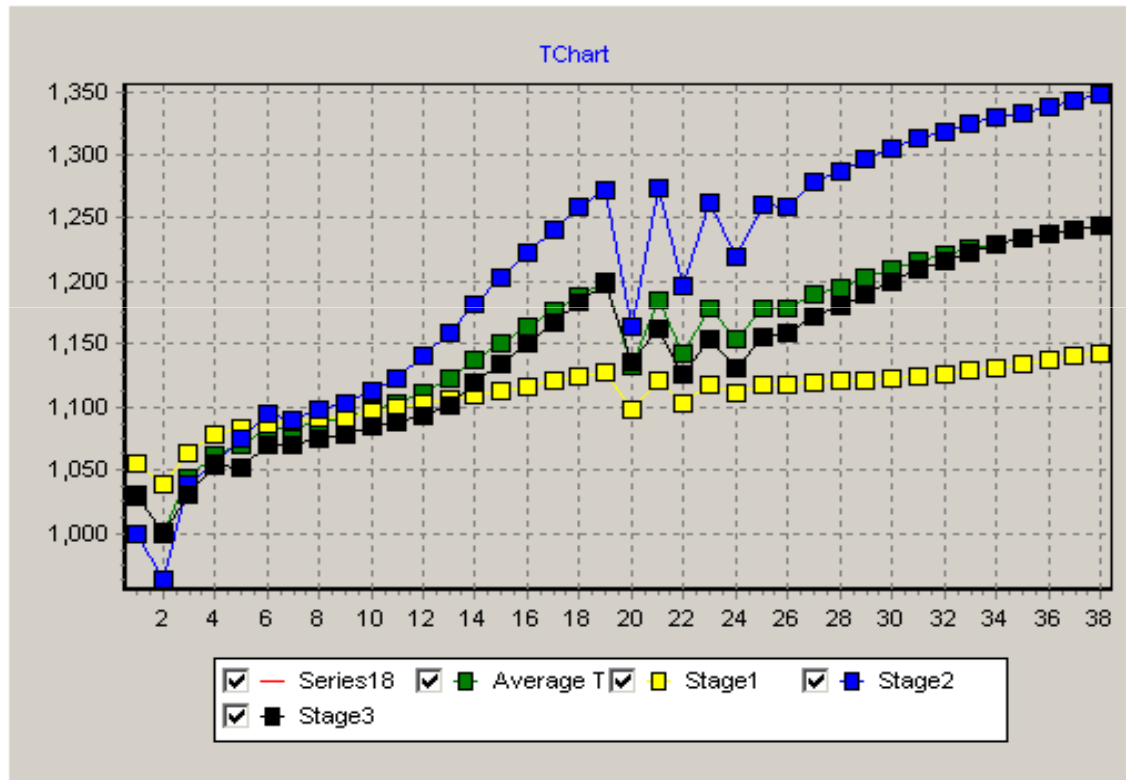

Conclusion

- Industrial end-processing of e-scrap works on large scale
- The complexity of EOL waste calls for new approaches to reactor modelling
- By introducing reactor segments into the model, non-equilibrium conditions can be simulated
- Need for better thermodynamic description for minor and micro elements in the system